

SERIES GRT

TWO STAGE GARAGE READY
RESIDENTIAL INFRARED HEATERS



SUPERIOR
RADIANT PRODUCTS

**HIGH
EFFICIENCY**
FUEL SAVINGS
UP TO 50%

Redesigned reflector with
integrated deco grille included



Keep your garage or workshop
warm and comfortable with
**SRP's high efficiency
two stage infrared heater**

FEATURES

- **UNPACK, HANG, CONNECT**
It's as easy as 1, 2, 3.
- Two-stage configuration input rate
high 45,000 and low 30,000 BTU/h
- Natural Gas and LPG
- Hi/Lo indicator lights
- Smart Control ready terminal
- Thermal efficiencies above 82%
- Preassembled construction
 - no loose parts
 - simplified installation
- 8' horizontal vent kit included
- Gas flex connector, shut-off valve,
and deco grille included
- Ceiling mounting bracket* included
- Direct spark ignition (DSI)
- Self diagnostic ignition module
- **Balanced flue construction** (Wall Venting)
 - one wall opening
 - maximum safety
 - minimum installation costs
- Hang horizontal or at 45 degrees
- CSA approved for outdoor use
- Vertical vent adapter kit available

*Hanging Chain kit Not Included

SAVING ENERGY FOR FUTURE GENERATIONS
WWW.SUPERIORRADIANT.COM

SERIES GRT INFRARED HEATERS SPECIFICATIONS

MODEL	CTRY	HI FIRE	LO FIRE	WEIGHT	DIMENSIONS
GRT45NC/PC	CAN	45,000	30,000	100 lbs (45kg)	17.5" x 8" x 118"
GRT45NU/PU	USA	45,000	30,000	100 lbs (45kg)	17.5" x 8" x 118"

ELECTRICAL SUPPLY	120 VAC 60 Hz 1A plug connector
GAS CONNECTION	1/2" NPT, NG or Propane
TUBE DIAMETER	Combustion air 4" Flue 2" (Concentric)
MINIMUM GAS INLET	Nat Gas 5.0" W.C. LPG 11.5" W.C.

STANDARD EQUIPMENT INCLUDES

- Pre-assembled burner and heat exchanger
- Ceiling mounting bracket*
- Gas connector & shut-off valve
- Deco grille
- 8' Horizontal venting



OPTIONAL EQUIPMENT SOLD SEPARATELY

- Thermostat 2-stage
- Vertical venting kit
- Horizontal elbow vent terminal
- Protective cover for outdoor installation
- *Hanging chain kit

APPROVAL STANDARDS

The Series GRT heater by Superior Radiant Products has been specifically designed for residential garage and workshop applications and approved to CSA's stringent residential requirements.

Series GRT high thermal efficiency 82+% combines with radiant's sun-like warmth keeping people comfortable at lower thermostat settings, resulting in fuel savings of up to 50% over conventional forced - air heaters.

BALANCED FLUE CONSTRUCTION

The flue pipe of the Series GRT heater by Superior Radiant Products is concentrically inside the combustion air inlet pipe.

This construction:

- Preheats the combustion air, making the Series GRT heater the most efficient heater of its class.
- Limits wall penetrations to one 4 inch hole, making installation simple and economical.
- Exposes inlet air and outlet gases to the same pressure conditions resulting in unparalleled safety and trouble-free operation.

DIMENSIONS (Inches)

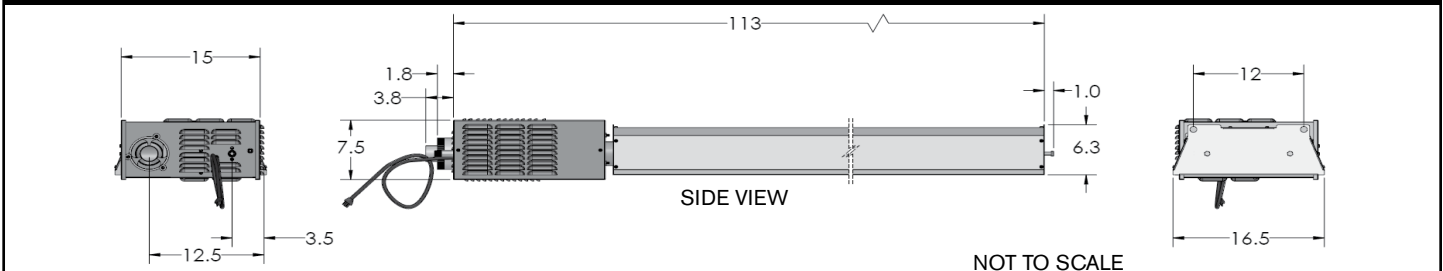

CLEARANCES TO COMBUSTIBLES (Inches)

CONFIGURATION	DIMENSION	45,000 BTU/HR
Standard	A	2"
	B	18"
	C	50"
	D	18"
45° Tilt	A	3"
	B	3"
	C	48"
	D	48"
Vented	End	5"

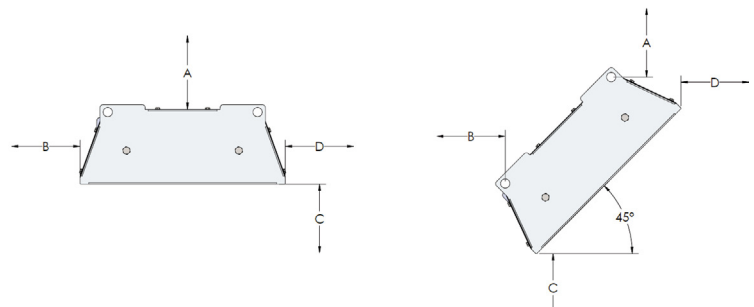

Visit our website for I/O manual, specifications, and submittal data.



SUPERIOR
RADIANT PRODUCTS



Superior Radiant Products Ltd.
563 Barton Street
Stoney Creek, ON L8E 5S1 Canada

Superior Radiant Products Inc.
315 N Madison Street
Fortville, IN 46040 USA

1 800 527 HEAT(4328) | tel 1 905 664 8274 | fax 1 905 664 8846
sales@superiorradiant.com | www.superiorradiant.com

SAVING ENERGY FOR FUTURE GENERATIONS

DISTRIBUTOR